



# Operation Manual

## The Flex-Chlorinator



Advanced Water Filtration  
For a Thirsty World.

---

# Table of Contents

|  |           |
|--|-----------|
| <b>Operation and Maintenance Safety.....</b> | <b>4</b>  |
| <b>Chemical Preparation.....</b>             | <b>5</b>  |
| <b>Operation.....</b>                        | <b>7</b>  |
| <b>Pump Maintenance .....</b>                | <b>8</b>  |
| <b>Troubleshooting .....</b>                 | <b>9</b>  |
| <b>General Maintenance .....</b>             | <b>11</b> |
| <b>Warranty .....</b>                        | <b>12</b> |

---

# FORWARD

The Operator's Guide has been prepared to acquaint the owner/operator with this water filtration unit, its various controls, maintenance and safety instructions. It is valuable for the proper use of The Flex-Chlorinator and should be kept with the unit at all times.

Make sure you read and understand the content of the Operator's Guide.

For any questions pertaining to the warranty and its application, consult the WARRANTY section in this guide and/or a First Water representative.

The information and component descriptions in this guide are accurate at the time of writing.

The illustrations in this guide represent the typical assembly and operation of the unit, but may not represent the full detail or exact shape of the parts.

It is understood that this guide may be translated into another language. In the event of a discrepancy, the English version shall prevail.

Specifications are given in the SAE U.S. system with SI metric given in parenthesis. Where precise accuracy is not required, some conversions are rounded.

First Water Systems, Inc.  
[www.firstwaterinc.com](http://www.firstwaterinc.com)  
[info@firstwaterinc.com](mailto:info@firstwaterinc.com)  
(770) 442-8257

---

# Operation and Maintenance Safety

NEVER position the Flex-Chlorinator directly over the Chlorine Dilution Container. The suction hose from the Chlorine Dilution Container to the Flex-Chlorinator should fall below the top of the container, then rise back up to the injector (see installation diagrams).

NEVER leave the Flex-Chlorinator or water lines full of water during freezing temperatures. Visually inspect the Flex-Chlorinator and water system for leakage.

## Warning! Risk of Chemical Overdose

To reduce risk, follow proper installation methods and instructions. The point of chemical injection should be beyond all pumps, filters and heaters.

NEVER use chlorine with fragrance, perfume or detergent additives.

## Notice:

This injection system and its components have been tested for use with Sodium Hypochlorite (5-15%).

The Flex-Chlorinator provides a means of delivery for chemicals in general. First Water Systems, Inc. does not suggest or recommend ways or procedures for using any chemical.

First Water Systems, Inc. is not responsible for injury incurred by the misuse or improper handling of chemicals.

---

# Specifications

## Water Motor Specifications

Water Flow.....1GPH - 13GPM

Pressure.....2 psi - 80 psi

Max. Temp.....110 F (43.3 C)

---

# Chemical Preparation

The presence of chlorine residual in drinking water indicates that:

- 1) a sufficient amount of chlorine was added initially to the water to inactivate the bacteria and some viruses that cause diarrheal disease; and
- 2) the water is protected from recontamination during storage.

The presence of free residual chlorine in drinking water is correlated with the absence of disease-causing organisms, and thus is a measure of the potability of water.

The recommendations of the CDC Safe Water System (SWS) are as follows:

1. At 30 minutes after the addition of sodium hypochlorite there should be no more than 2.0 ppm of free chlorine residual present (this ensures the water does not have an unpleasant taste or odor).
2. At 24 hours after the addition of sodium hypochlorite to containers that are used by families to store water there should be a minimum of 0.2 ppm of free chlorine residual present (this ensures microbiologically clean water).

Further, the CDC Safe Water System recommends testing residual chlorine by the following methods:

1. Pool test kits
2. Color wheel test kits
3. Digital Chlorimeters

For more information please visit <http://www.cdc.gov/safewater>

Note: This information is provided as a courtesy of First Water Systems, Inc. First Water Systems, Inc. does not suggest or recommend ways or procedures for using chlorine in drinking water. Local regulations should be consulted before the use of chlorine in drinking water.

# Chemical Preparation

The Flex-Chlorinator is designed to inject a chlorine dilution into your water supply to provide a residual amount of chlorine in your water. Because First Water Systems can not guarantee the quality of water going through the Flex-Chlorinator, the following guidelines are for the total chlorine demand of your water, not the final desired residual chlorine.

1. Open the case and remove the Chlorine Dilution Containers.
2. Follow the chart below to achieve the proper dilution of household bleach. CAUTION: never use bleach with fragrance, perfume, detergent or any other additives.

| Using Household Bleach<br>(5.25% Sodium Hypochlorite) |     |         |          |  |
|---|-----|---------|----------|--|
| Step 1:   |     | Step 2: |          | Step 3:                                      |
| For a CL demand of                                    |     | Add     |          |  |
| 0.5   | ppm | 1.53    | oz of CL | Then add water to reach a total of 5 gallons |
| 1   | ppm | 3.06    | oz of CL |  |
| 2   | ppm | 6.15    | oz of CL |  |
| 3   | ppm | 9.28    | oz of CL |  |
| 4   | ppm | 12.43   | oz of CL |  |
| 5   | ppm | 15.61   | oz of CL |  |
| 6   | ppm | 18.82   | oz of CL |  |
| 7   | ppm | 22.07   | oz of CL |  |
| 8   | ppm | 25.35   | oz of CL |  |
| 9   | ppm | 28.66   | oz of CL |  |
| 10  | ppm | 32.00   | oz of CL |  |
| 11  | ppm | 35.38   | oz of CL |  |
| 12  | ppm | 38.79   | oz of CL |  |

3. Position the Flex-Chlorinator in line with your water treatment system after all pumps, filters and heaters; before your distribution/storage point.
4. Place the Chemical Pump Suction Tube into the Chlorine Dilution Container.
5. Make appropriate connections as shown on the next page.

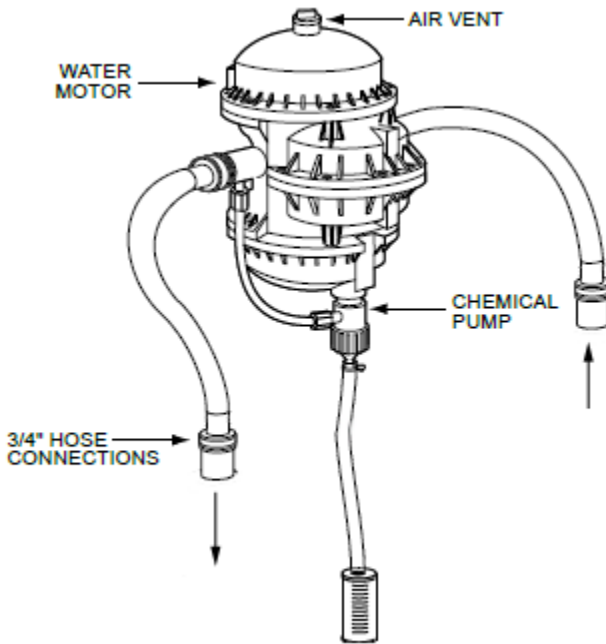

---

## Operation

### Starting the Unit

1. Be sure the chemical pump is locked into the bottom of the water motor. (1/4 turn to the right).
2. Open any valves between the Flex-Chlorinator and distribution points.
3. Open any valves between the water source and the Flex-Chlorinator.
4. Open air vent until all trapped air is released.
5. Warning! The Chlorine Dilution Container must be continually monitored to ensure your water treatment system does not continue to operate after the chlorine solution is depleted.
6. When the water motor is working properly, you should hear a clicking sound.

### Stopping the Unit

1. Close any valves between the water source and the Flex-Chlorinator to stop the flow of water.
2. Close any valves between the Flex-Chlorinator and water distribution points.

# Pump Maintenance

## Installing the Pump to the Water Motor

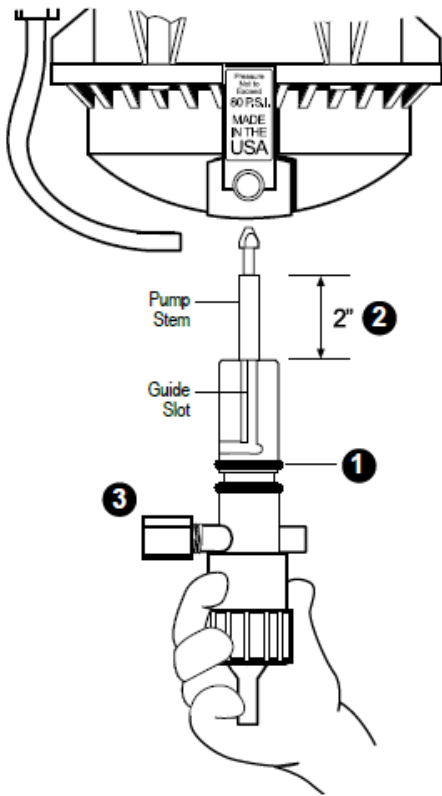

1. Lubricate "O" rings on pump housing with any food grade lubricant when pump is removed from motor.

NOTE: a light coating of lubricant is all that is required.

2. Make sure the pump stem is pulled all the way out (about 2"). Push the pump up into the water motor, and turn 1/4 turn clockwise, port to front.

NOTE: the guide slot must be aligned to fit into the key on the inside of the water motor.

3. After installing pump into bottom of water motor - loosen Jaco nut on pump and insert hose into fitting. Re-tighten Jaco nut.

## Removing the Pump from the Water Motor

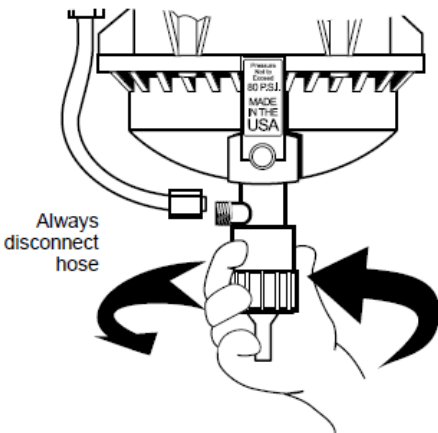

1. Make sure the water is turned off, and water pressure in the water motor is released - this is done by loosening the Air Vent (pressure relief valve) on the top of the water motor and turning off the water flow.

NOTE: Do Not Remove Air Vent.

2. Turn pump counter clockwise 1/4 turn, then pull down.

NOTE: always disconnect hose from pump before removing.



# Troubleshooting

## Pump Motor Diagram:

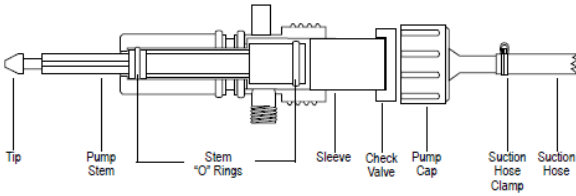

**Problem:** Water Motor does not click. Water does not flow past unit.

- Cause: No water flow to motor.
- Solution: Check that water is flowing to Flex-Chlorinator.
- Cause: Incoming water is connected to the outlet side of the pump motor.
- Solution: Verify that the incoming water is connected to the inlet (right side) of the pump motor.

**Problem:** Water Motor does not click. Water does flow past unit.

- Cause: Water motor is in “bypass” due to damaged parts on the inside of water motor or excessive wear of moving parts.
- Solution: Contact First Water for support.

**Problem:** Motor click a few times then stops.

- Cause: Unit is in bypass condition.
- Solution: Shut off water. Relieve pressure at the air vent. Restart water.
- Cause: Clogged chemical feed tube.
- Solution: Inspect tube for blockage.
- Cause: Motor may be in bypass due to damaged internal parts.
- Solution: Contact First Water for support.
- Cause: O-Ring on pump stem may have excessive wear.
- Solution: Contact First Water for support.

---

# Troubleshooting

**Problem:** Motor clicks, but chlorine is not drawn up the suction hose.

- Cause: Pump cap is loose.
- Solution: Hand tighten pump cap.
- Cause: Pump stem is not engaged into the piston clip in the water motor.
- Solution: Remove pump, check for broken or worn pump stem at tip. Pump stem must be pulled out completely before being inserted into the water motor.
- Cause: Damaged pump.
- Solution: Contact First Water for support.

**Problem:** Chlorine is drawn up in the suction hose, but then falls back down.

- Cause: Vacuum leak.
- Solution: Check suction hose to ensure a tight fit. Prime pump by hand and verify that the solution stays up in the suction hose.

---

# General Maintenance Tips

## Water Motor

1. Do not let unit freeze.
2. Periodically clean or replace chemical hose (hose between pump & water motor) and connectors. Chemical buildup will cause the unit not to pump.
3. If chemical pump becomes hard to remove from bottom of water motor, clean inside of opening on bottom cap of water motor with toothbrush & white vinegar.

## Chemical Pump

1. Clean pump after use by running 5 gallons of clean water through the pump, or by removing the pump and hand cleaning individual parts.

## Other

1. Keep your stock solution bucket clean of foreign particles and trash.
2. Keep the suction hose filter off the bottom of the stock solution bucket, insoluble particles may cause clogging and accelerate wear.

---

## Limited Warranty

First Water Systems, Inc. warrants this product against defects in material or workmanship for one year from the time of delivery. First Water Systems, Inc. will pay labor and standard freight costs for warranty service for a period of 90 days from the time of delivery. This warranty does not cover consumable type items, such as the unit's filters, (pleated, carbon-block, KDF filters), and the ultraviolet bulb/quartz tube assembly. Warranty of product is null and void with operation of unit with filterers and UV bulbs, pumps, or other replacement parts not approved by First Water Systems, Inc.

First Water Systems, Inc.'s sole obligation under said warranty is to repair, or at its option, replace the defective part. The buyer shall have no other remedy. All special, incidental and consequential damages are excluded.

The warranty shall be voided by alterations of equipment except by First Water Systems, Inc., or tampering with, improper installation or maintenance, accident or misuse. This warranty expressly excludes all damage to these products resulting from careless or neglectful transportation.

First Water Systems, Inc., shall in no event be responsible for any warranty work done without first obtaining First Water Systems, Inc.'s written consent.

This warranty is made expressly in lieu

of all other warranties, expressed or implied. including any implied warranties or merchantability or fitness for particular purpose. No employee, agent, franchise, dealer or other person is authorized to give any warranties of any nature on behalf of First Water Systems, Inc. except as provided herein. First Water Systems, Inc. shall have no liability or responsibility to customer or any other person or entity with respect to any liability, loss of damage caused or alleged to be caused directly or indirectly by "equipment".

Notwithstanding the above limitations and warranties, First Water Systems, Inc.'s liability hereunder for damages incurred by customer or others shall not exceed the amount paid by customer for the particular "equipment" involved.

First Water Systems, Inc. can not and will not be held liable for any sickness or illness due to the consumption of drinking water from any water filtration system supplied by First Water Systems, Inc. Since we at First Water Systems, Inc. do not have any control over the quality, cleanliness or contaminates that are present in the water entering into any of the First Water Systems, Inc. filtration products; or the vessels that water is contained in after treatment, we claim only CLEANER AND SAFER, not CLEAN AND SAFE, water.